

SPORTSMAN II™

INSTALLATION INSTRUCTIONS



Read these instructions thoroughly before installation and keep for future reference.

TABLE OF CONTENTS

1	Check Your Order	3	Base Cabinets
1	Tools You'll Need	4	Closets
2	Hardware We Supply	5	Installing Your Cabinets
2	Before You Begin	5	Countertop
3	Tool Boxes	5	Caring For Your Cabinets
3	Overhead Cabinets	6	Frequently Asked Questions

CHECK YOUR ORDER

When your order is delivered, remove the packing material and thoroughly inspect all cabinets for damage. Every cabinet is inspected and free of defects when it leaves our facilities. If you believe your order has been damaged, sign the bill of lading as Possible Concealed Damage or Damage and contact your Moduline sales representative.

TOOLS YOU'LL NEED

- #2 Phillips Screwdriver
- Cordless Drill/Driver with #2 Phillips bit
- 3/8", 7/16" & 3/4" Wrenches or Ratchets
- Tape Measure
- Level
- Carpentry Square
- Masking Tape
- Microfiber Cloth
- Glass Cleaner
- Stainless Steel Polish

HARDWARE WE SUPPLY

- A. 10-24 x 3/8" Self-Tapping Screws for Assembling Base Cabinets & Closets
- B. 1/4-20 x 1/2" Bolts & Hex Nuts for Installing Shelves
- C. 1/4-20 x 3/4" Bolts & Hex Nuts for Joining Cabinets
- 1" Wide Double-Sided Tape for Installing Countertops
- Horseshoe Shims for Leveling Cabinets

Because each installation is unique, Moduline does not supply wall mounting hardware.

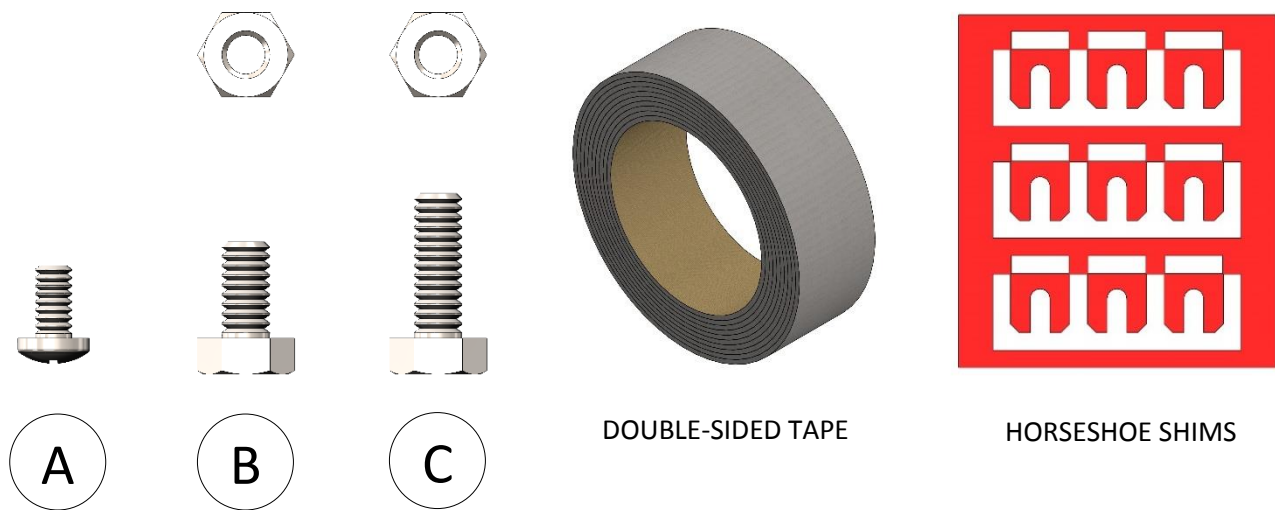

BEFORE YOU BEGIN

WARNING: HEAVY OBJECTS. Lifting can cause muscle strain or back injury. LIFT WITH 2 PEOPLE.

Unbox your cabinets and set them aside, out of the way. We recommend reusing the cardboard packaging to protect the floor from damage as you move your cabinets around. **Do not remove** the protective vinyl from your cabinets until you've finished assembling them. You'll have to peel it back in places to assemble the base cabinets and closets, and when you join the cabinets together, but leave it on where possible to safeguard against accidental scratches.

No construction is going to be perfectly level and you'll need to shim your cabinets to keep them square. Use a level to identify the high point in the floor where your cabinets will eventually go. You should plan to start here when joining your cabinets together to make shimming them easier.

Locate and mark the center of your wall studs. You can locate your studs with a stud finder, but don't trust it to determine the centerline. Instead, using a thin nail or drill with a small bit, make holes around where you think each edge of the stud is. Repeat this until you hone in on the exact edge of the stud. This will require several holes spaced close together. Once you've found the edges, you can mark the center of the stud. Continue this process to locate all wall studs behind your cabinets.

TOOLBOXES

Toolboxes are shipped fully assembled.

You will need to remove the drawers before you can install your toolbox. Open a drawer, hold down the release levers located on the inside of both slides (see right) and pull the drawer out of the toolbox. Set the drawers aside and reinsert them after installation is complete.



OVERHEAD CABINETS

Overhead cabinets are shipped fully assembled.

BASE CABINETS

Base cabinets require some assembly. Peel back protective vinyl from contact surfaces as you go.

DO NOT overtighten self-tapping screws. Sportsman II cabinets are assembled easily with self-tapping screws. Start your driver on a low clutch setting and gradually increase it until the screws drive in completely. Overtightening them will cause the holes to strip, and you'll need to use a #10 nut and bolt instead (not provided). Reset your driver's clutch this way each time you change batteries.

Assembly Steps:

1. Attach both sides with (7) 10-24 self-tapping screws **[A]** each. To make this easier, you can first temporarily bolt the sides on with $\frac{1}{4}$ -20 x $1\frac{1}{2}$ " bolts **[B]** through the shelf holes.
2. Put the braces in between the sides and fasten each with (4) 10-24 self-tapping screws **[A]**.

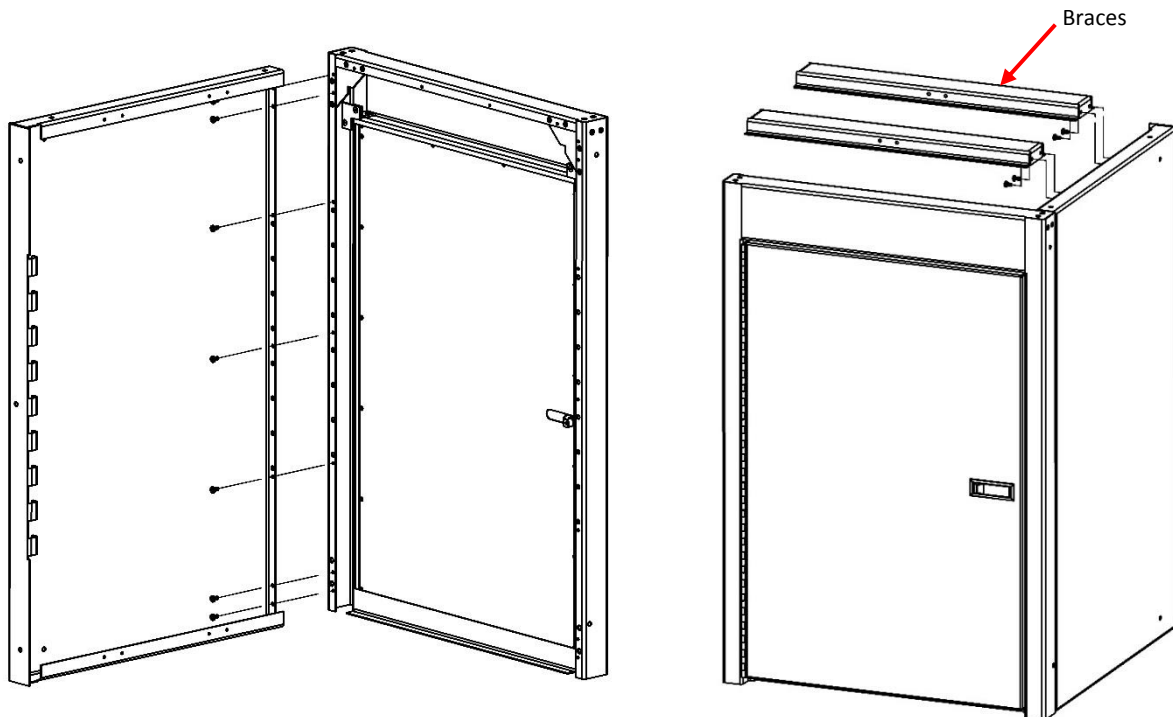

CLOSETS

Closets require some assembly. Peel back protective vinyl from contact surfaces as you go.

DO NOT overtighten self-tapping screws. Sportsman II cabinets are assembled easily with self-tapping screws. Start your driver on a low clutch setting and gradually increase it until the screws drive in completely. Overtightening them will cause the holes to strip, and you'll need to use a #10 nut and bolt instead (not provided). Reset your driver's clutch this way each time you change batteries.

Assembly Steps:

1. Attach both sides with (14) 10-24 self-tapping screws **[A]** each. To make this easier, you can first temporarily bolt the sides on with ¼-20 x 1/2" bolts **[B]** through the shelf holes.
2. Put the closet top down between the sides and fasten with (11) 10-24 self-tapping screws **[A]**.

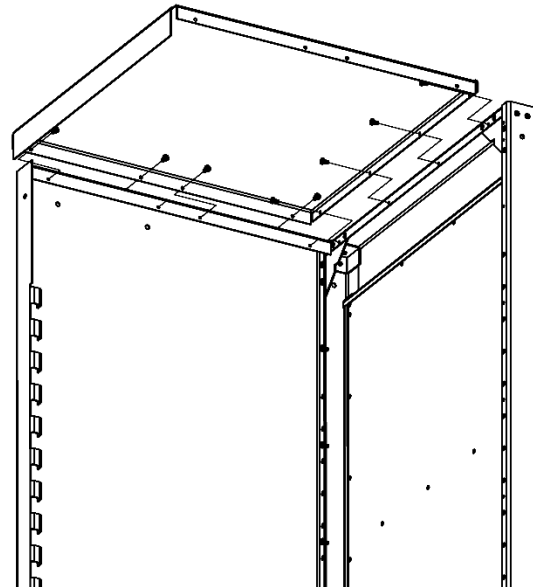
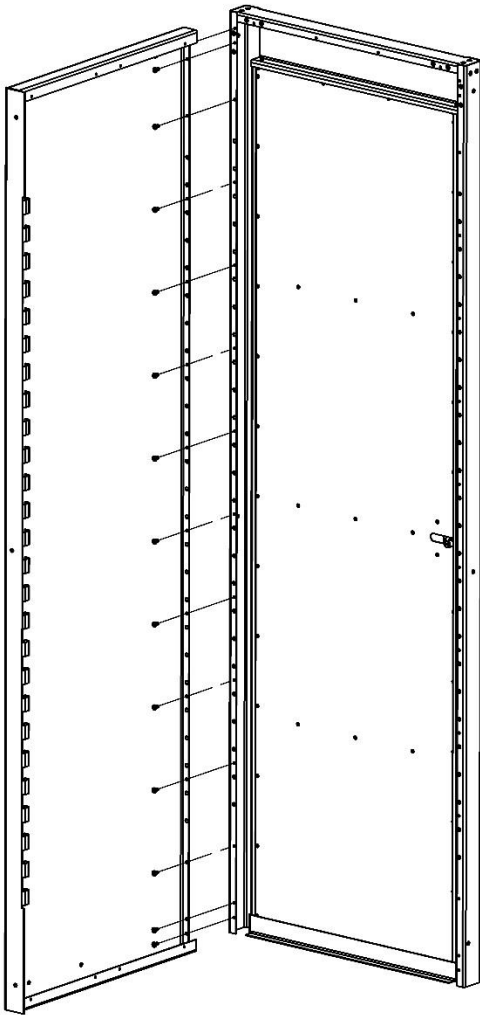

INSTALLING YOUR CABINETS

Start at the high point on the floor that you identified earlier. Put the first base cabinet or closet into place, shim and fasten it to the wall with appropriate hardware. **Do not use drywall screws.** The cabinets have pre-punched holes for mounting, but you may need to drill your own to line up with studs.

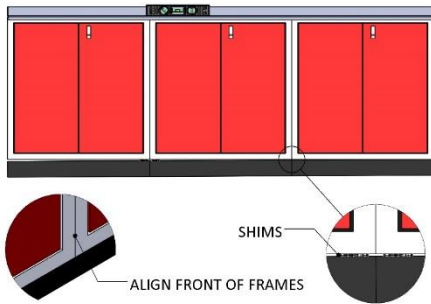

Put the next cabinet into place and attach it to the first with (4) ¼-20 x ¾” bolts [C]. Make sure the front frames are aligned. Then fasten it to the wall. For added rigidity, you can drill and fasten through the sides into the floor. Repeat for each base cabinet and closet in the combo.

Shim as you go to keep everything square and level. You can visually check for squareness, just make sure the space around each door is consistent.

Install the overhead cabinets. To attach an overhead to a closet you'll need to transfer the front mounting holes from the overhead to the closet. You can construct a box out of wood or reused packing cardboard to prop the cabinets up while you work.

If your combo has closets at both ends you may want to leave one closet for last, until after the countertop and overheads have been installed. It's easy to accidentally damage your cabinets while trying to slide the countertop or overheads between them.

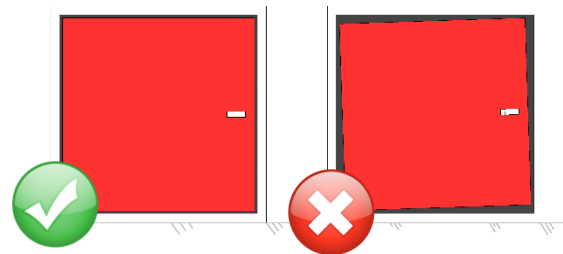

COUNTERTOPS

Dry fit the countertop to make sure you like how it fits before using any adhesive. Tape off any exposed surfaces—especially closet sides—that could be scratched while moving the countertop around.

Apply double-sided tape to the tops of base cabinets and tool boxes. Remove the backing from the tape to expose the adhesive. Spray the tape with glass cleaner to temporarily stop the tape from sticking. This will give you some time to align the countertop, but holds fast once the tape dries.

Set the countertop straight down into place. Apply even pressure to the countertop to smooth it out.

CARING FOR YOUR CABINETS

Remove any remaining protective vinyl once installation is complete. A little maintenance will keep your cabinets looking brand new.

To clean the cabinets and remove fingerprints use glass cleaner and a microfiber cloth.

To clean the countertops wipe with a microfiber cloth and a solution of water and a few drops of dish soap. Dry thoroughly. Use stainless steel cleaner to remove fingerprints and make the countertop shine.

Avoid using the following on your cabinets:

- ⊗ Abrasive Cleaners
- ⊗ Chemical Solvents
- ⊗ Strong Detergents
- ⊗ Cleaners with Bleach
- ⊗ Furniture Polish

FREQUENTLY ASKED QUESTIONS

Q: Why don't my cabinets have backs?

A: Backs are not available with Sportsman II cabinets.

Q: Do I have to use the pre-punched mounting holes or can I drill my own?

A: Holes are pre-punched for easy installation to a solid wall. However, when mounting to a studded wall you'll need to drill your own holes to catch the studs. Moduline recommends fastening to two studs per cabinet if possible.

Q: How do I install a countertop brace in the open space between cabinets?

A: The countertop brace has holes to bolt to the adjacent cabinets. Just be sure to put the side with 2 formed flanges in front for extra strength.

